



# CLASSIC™

TITANIUM SERIES  
Outdoor Wood Furnace



Titanium-enhanced  
Stainless Steel Firebox



*Keep the fire and mess outside*



*Warmth for your entire business*



*Burn less wood, deliver more heat*

As the outdoor wood furnace that set the standard for quality and revolutionized the industry, the Classic is the perfect choice for heating your business, shop, barn and more!

In the U.S., this appliance is for non-residential applications only.

**CentralBoiler.com**

# Heating your business, shop or barn with wood is good for your bottom line.

Since 1984, Central Boiler has been developing better designs to heat with wood. Today, Central Boiler is the largest outdoor wood furnace manufacturer because of the improvements they have made to give customers more efficient, cleaner burning and more cost-effective furnaces.



**PEACE OF MIND** Keep the fire outside and it eliminates the traditional indoor wood stove hazards. Burning wood indoors is inherently dangerous as there is a threat of a fire and carbon monoxide buildup.



**IMPROVED INDOOR ENVIRONMENT** The mess stays outside with a Central Boiler outdoor wood furnace. Anyone that has burned wood inside is familiar with the smoke, ashes, odors and soot that often occur. In addition, bringing wood indoors can bring in unwanted bugs, bark and dirt.



**FREEDOM TO DO MORE** Those that choose to heat with wood often do so because of the cost savings. With a Central Boiler outdoor wood furnace, it can take less wood to heat more space, so no matter what your costs and time are associated with acquiring your wood supply, using less wood means you'll have more time (plus save more money!) to do other things.



**STABILITY** Heat sources like propane, natural gas and fuel oil will always be susceptible to price fluctuations and are irreplaceable fossil fuels. Historically, the price of electricity trends only upward.



**SUSTAINABILITY** Harvesting wood with sustainable forestry practices helps to maintain a healthy ecosystem for wildlife habitats, aesthetics, soil and water quality, native biological diversity, and recreational opportunities. It can also significantly reduce the risks of costly wildfires.



*Heating with wood...*

*"It's the right thing to do!"*

## PRESERVES WILDLIFE HABITAT



Harvesting wood has a pruning effect on forests – planting new trees ensures wildlife will have a healthy habitat.

## SOIL AND WATER QUALITY



Reforestation reduces erosion risks and protects watersheds that are a source of the water we drink and use.



## What do you currently pay for heat?

### Cost per 100 million Btu

Cost per cord of seasoned red oak	\$	x	6.61	=	\$	Cost of fuel annually
Cost for one gallon of fuel oil	\$	x	892.9	=	\$	Cost of fuel annually
Cost for one therm of natural gas	\$	x	1250	=	\$	Cost of fuel annually
Cost for one gallon of propane	\$	x	1359	=	\$	Cost of fuel annually
Cost per kilowatt of electricity	\$	x	29300	=	\$	Cost of fuel annually

Appliance efficiency will affect annual fuel cost.  
Water heater savings up to an additional \$1200 per year.

### AESTHETICS AND RECREATION



Sustainable forestry makes more room for new and healthier growth through reforestation.

### REDUCES FOREST FIRES



By harvesting old and dead trees that can easily burn, it can significantly reduce the risks of costly wildfires.





Many dealers offer services to install the complete system for you. Authorized Central Boiler dealers have all the supplies and accessories needed for installation and maintenance. Some customers choose to install the furnace themselves following the installation manual.

## So advanced, it's simple.

### How a Central Boiler outdoor wood furnace works.

A Central Boiler outdoor wood furnace burns wood to heat water. The heated water is circulated through insulated underground pipes called ThermoPEX to the buildings being heated. Heated water can transfer its heat energy through one or more heat exchangers.

**LOCATION** The Central Boiler outdoor wood furnace is located outside, typically 30 to 200 feet (but as far as 500 feet) away.

**CIRCULATION** The furnace contains a high volume of water that surrounds the furnace firebox and heat exchanger. This heated water is circulated to buildings through insulated underground pipes which is a highly efficient way to move heat over distances.

**INTEGRATION** Central Boiler outdoor wood furnaces are designed to work with your existing heating system. Water-to-air or water-to-water heat exchangers or direct circulation conveys the heat into the structure's forced-air furnace, radiant baseboard or radiant floor heating system. This allows you to control the heat simply with your thermostat.

**UNLIMITED HOT WATER** When you install a heat exchanger on your domestic water heater, you can enjoy unlimited hot water and the savings from turning your water heater off.

**HEAT MULTIPLE BUILDINGS** Unlike an indoor wood stove, a Central Boiler outdoor wood furnace has the ability to heat multiple buildings such as a garage, workshop, shed, greenhouse or barn. It can even be used to heat a swimming pool or hot tub.

---

### Installation is a breeze.

Connect the piping and heat exchangers to your existing heating system and the Classic is ready to go to work.

Find additional information about how outdoor furnaces work, installation scenarios, and more at [CentralBoiler.com](http://CentralBoiler.com)

# Smart features designed with you in mind.

Easier installation, convenient operation and choices to fit your lifestyle.

## Optional Dual Fuel System

The optional Dual Fuel system provides you the flexibility and choice to operate the furnace with fuel oil, natural gas or propane as a backup.

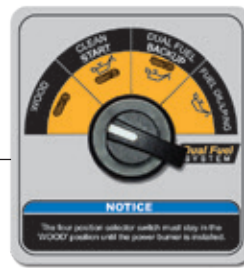

## Choice at the turn of a switch.

Choose the mode that best works for you. Of course, there's a mode for operating with wood only, the most economical choice. You can choose to use your dual fuel to cleanly start the fire and serve as an automatic backup, use it as a backup only or operate solely with your backup fuel.



## Dual Fuel Burner

The optional Dual Fuel Burner installs easily on Dual Fuel Ready Classic models.

Learn more at  
[CentralBoiler.com](http://CentralBoiler.com)



## Digital Controller

Set your water temperature setpoint (the water temperature you want the furnace to maintain) and the controller does the rest. A simple switch lets you select if you want the lights on or off, or controlled automatically with the integrated photo sensor.



## Side Panel Pump Cover

Hinged side panel cover makes installing and accessing your pumps, power disconnect and even your owner's manual easy. The cover can even be locked for added safety and security.



## Insulated Firebox Door

Unequaled in the industry, the Classic's firebox door is built to last with its thick, heavy-duty hinges, durable steel construction, and Central Boiler's Cam Loc® door closure that ensures a tight seal each time the door is closed.

# Engineered to the highest standards...ours.

## **A** Easy Installation

Every Classic model is designed with a **skid base** framework to make installation easy with or without a cement foundation. Simply set the furnace in place, connect the piping and heat exchangers to your existing heating system, and the Classic is ready to go to work.

## **B** Easy Loading

Loading wood is easy with the large **firebox door**. Ergonomically designed, the door is easy to open and close, and is insulated to lock in the heat.

## **C** Convenient Operation

The draft control in the firebox door automatically maintains the water temperature to the chosen settings on the controller.

## **D** Burn Less Wood

A hallmark of Central Boiler furnaces for over 30 years, **spray-on urethane** is the **ultimate airtight, waterproof** insulation that locks the heat in to reduce wood usage, even at temperatures of -35°F or colder. It provides 2-3 times the effective **R-value** of conventional fiberglass batt insulation. Fiberglass batt insulation also settles and compresses over time.



Helpful installation videos at  
[CentralBoiler.com](http://CentralBoiler.com) > [Explore](#) >  
[Videos](#) > [DIY](#)

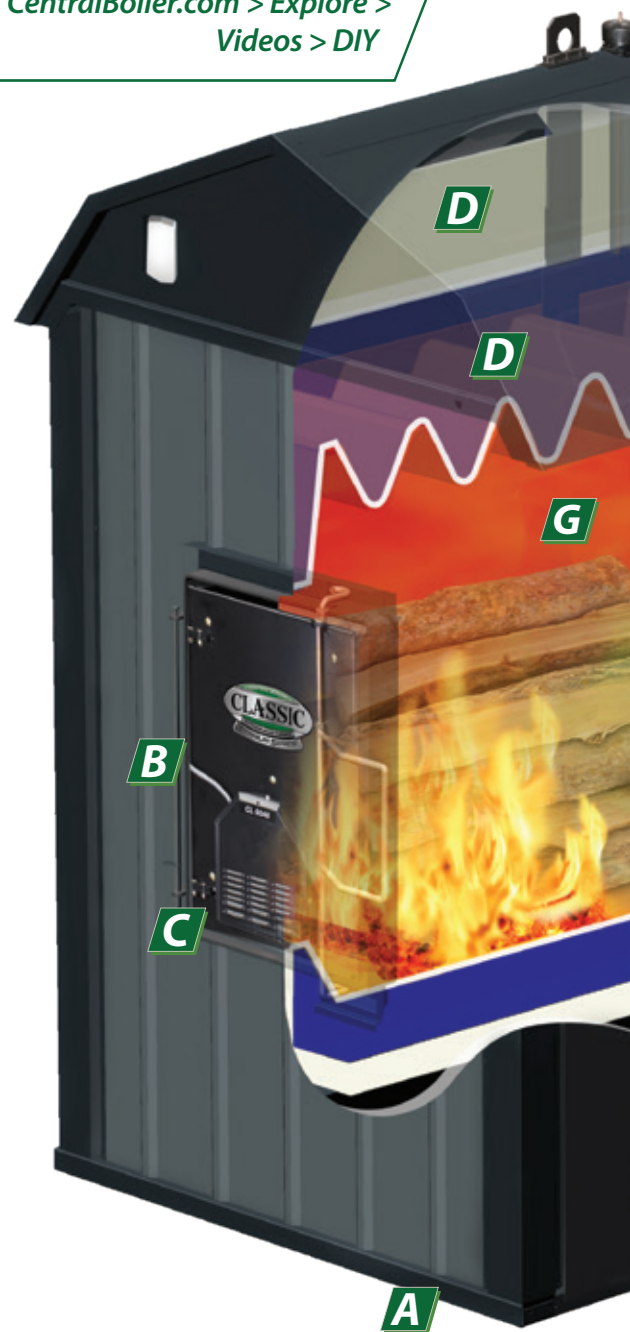



Watch the Urethane Foam Insulation video  
[CentralBoiler.com](http://CentralBoiler.com) > [Explore](#) > [Videos](#)

Comparing Insulation		
	Urethane	Fiberglass Batt
Waterproof	✓	-
Airtight	✓	-
Effectively covers all surfaces	✓	-
Maintains R value	✓	-
Higher R value	✓	-
Doesn't compress	✓	-

Learn more at  
[CentralBoiler.com](http://CentralBoiler.com)

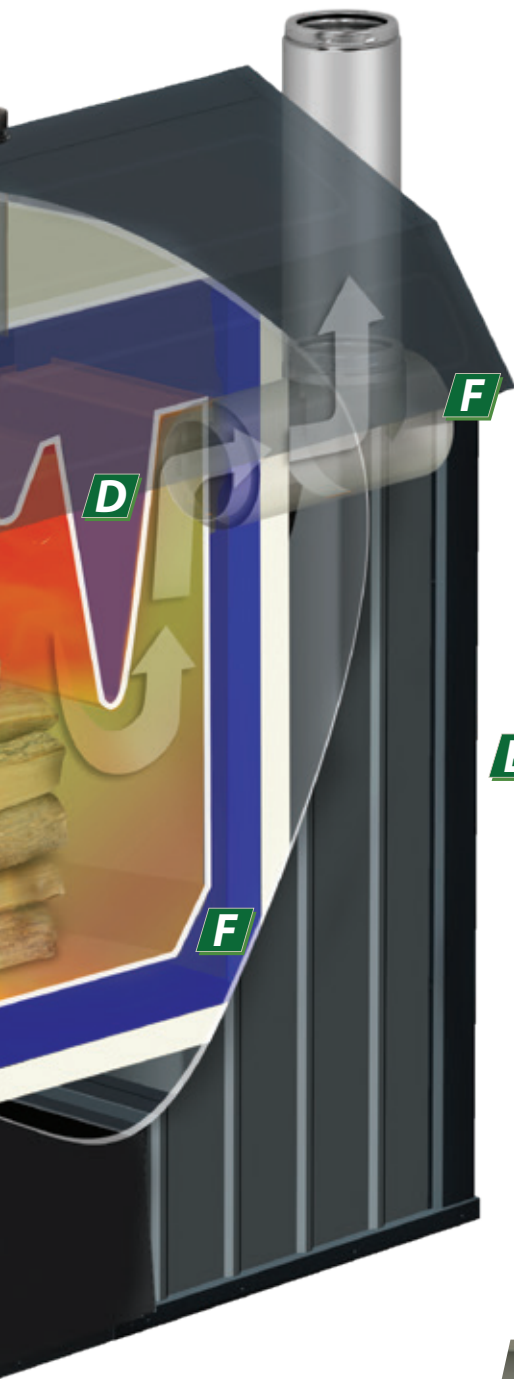



## **D** Burn Less Wood

**RippleTop®** and **HeatLock Baffle®** are proprietary design elements of each Classic firebox. They increase the heat transfer area in the firebox and trap the heat and gases in the top of the firebox for the most complete combustion and heat extraction. That means you get more heat energy out of your wood supply.

The **water jacket capacity** provides a proven balance between firebox volume and water capacity for optimum performance and safety.

## **E** Durability and Reliability You Can Count On

Classic furnaces are manufactured with attention to detail. From a **rectangular firebox** that won't collapse like round fireboxes can, to overlapped steel siding and high-quality coated fasteners, every component must meet the highest standards...ours.

## **F** Easy Inspection and Maintenance

**Large firebox doors** and an **angled firebox base** make ash removal easy and fast. The rear-exiting design of the chimney eliminates leaks and corrosion that through-the-roof designs can experience. The Classic's chimney is designed for easy inspection.

## **G** Stainless Steel Firebox

Constructed of titanium-enhanced stainless steel (proven to be the best, most forgiving firebox material), the firebox is extremely resistant to corrosion. Burning wood that is less than perfectly seasoned will have no adverse affects compared to what a non-stainless steel firebox can experience.

*Central Boiler recommends burning seasoned wood when possible because dry wood burns better and provides more energy for heating. You'll burn less wood, saving you more money and time. That is, after all, what you want your outdoor furnace to do.*

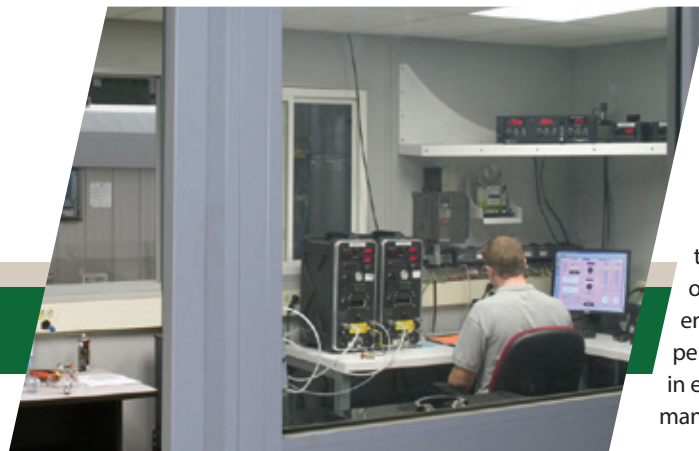

Central Boiler's Research and Development department is home to one of the most complete state-of-the-art testing laboratory in the industry. Since 1984, its goal has been to develop, engineer, test and refine a wide range of quality heating products to ensure Central Boiler quality, performance and value are in every outdoor furnace manufactured.

# Sample Applications

## Domestic Hot Water Flat Plate

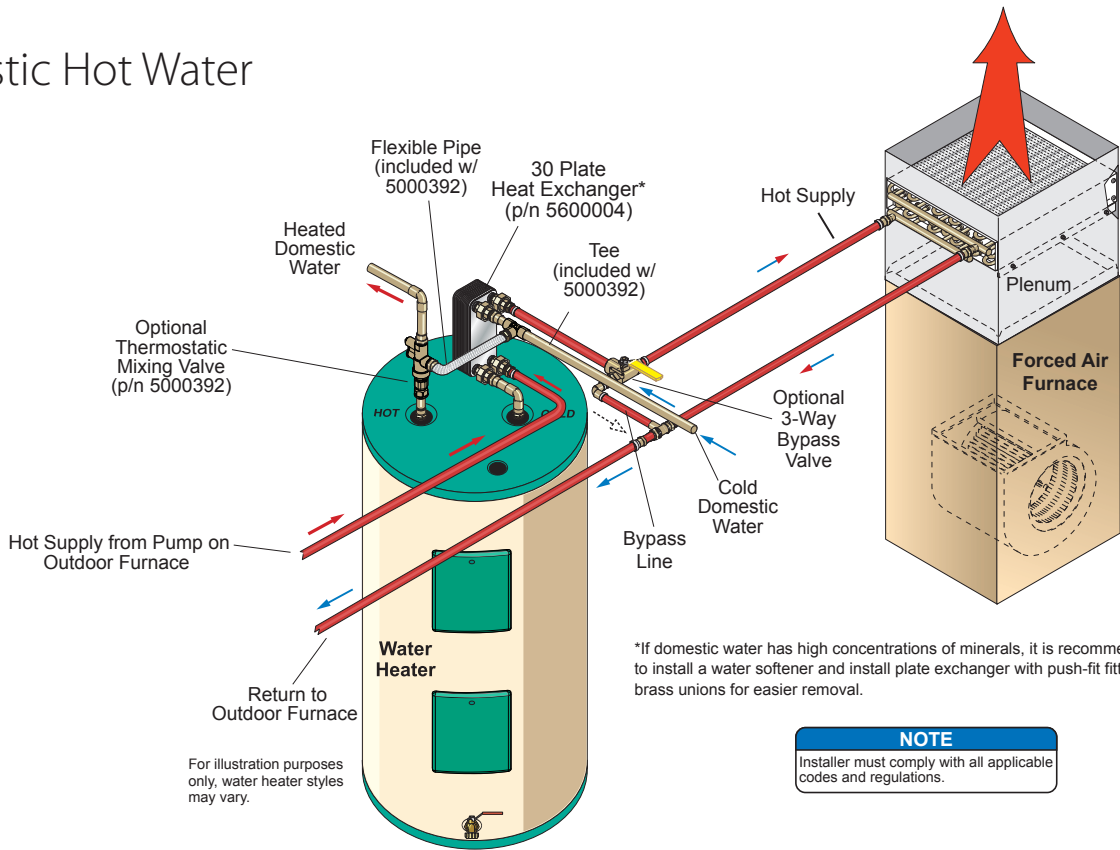

## Greenhouse Applications

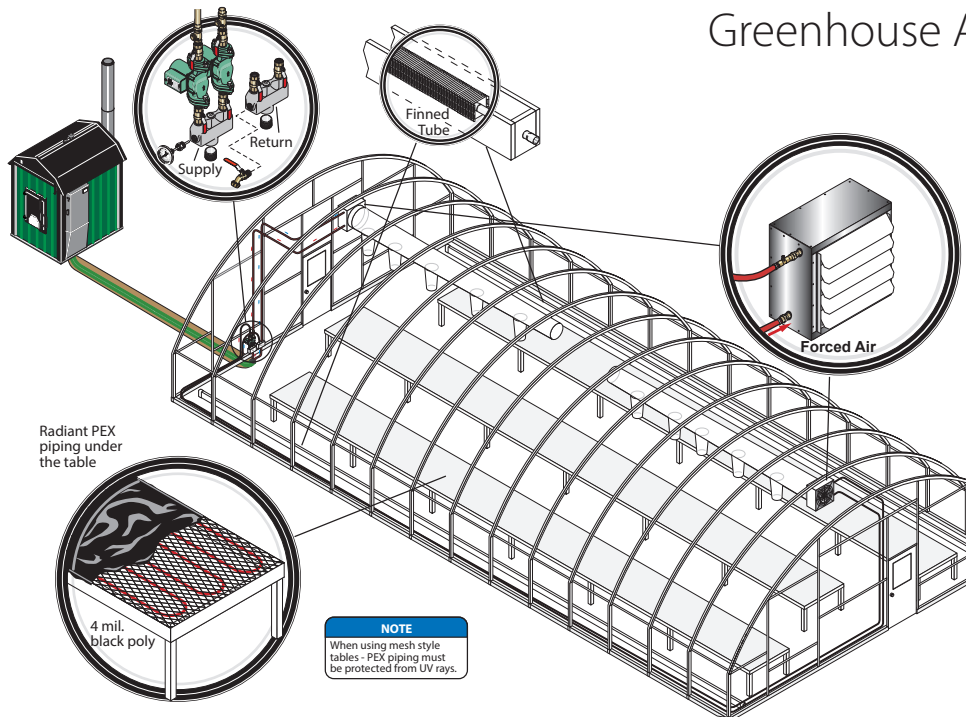

# Heating Multiple Buildings

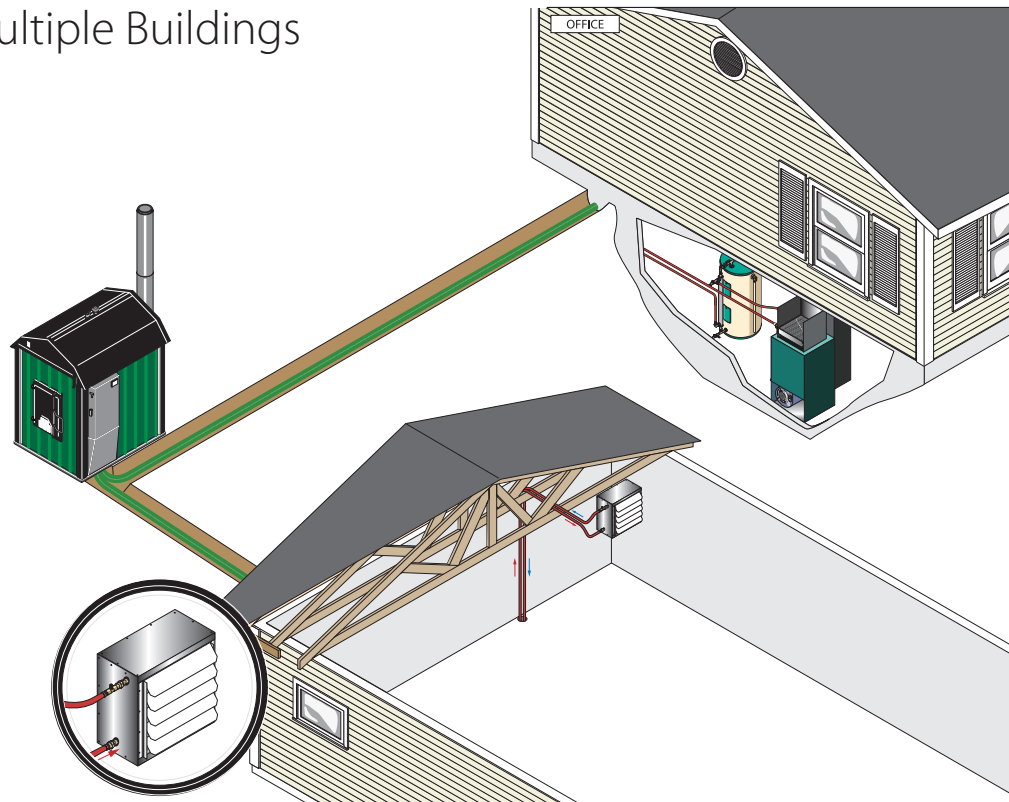

# Multi-Zone In-Floor

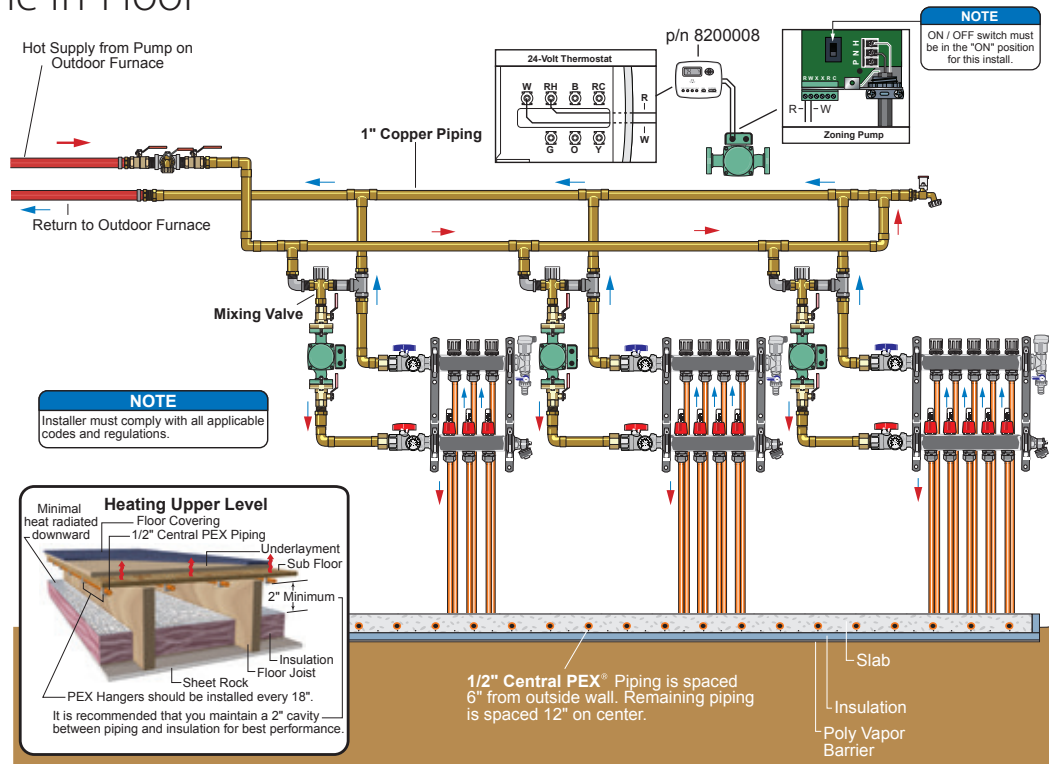

Find more applications at [CentralBoiler.com](http://CentralBoiler.com)



## ThermoPEX<sup>®</sup> Insulated Piping System



Choose ThermoPEX. Because performance matters.

Choosing the best insulated piping system for your outdoor furnace is imperative if you want to lower heat loss and reduce the amount of wood you'll burn. The ThermoPEX insulated piping system from Central Boiler is a proven system that saves energy and maximizes the efficiency of your outdoor furnace.

**ENERGY EFFICIENT** – ThermoPEX saves energy and maximizes efficiency. The thick waterproof jacket keeps moisture out and the inner urethane insulation locks the heat in. Greater system efficiency maximizes the delivery of heat from each pound of wood so you will burn less wood compared to a system using inferior insulated piping.

**RELIABILITY** – ThermoPEX is a proven, time-tested insulated piping system.

**FLEXIBLE AND INSTALLS FAST** – Easy to handle and easy to install, requiring only a narrow trench approximately a foot deep.



**IN A HURRY?** Some ThermoPEX can be UPS shipped - see dealer for details.



## Central Boiler authorized system parts and accessories

For the maximum performance and life of your outdoor furnace, always insist on using Central Boiler authorized system parts and accessories.

Your Central Boiler dealer can provide you with a complete selection of parts and accessories to simplify the installation and maintenance of your system.

To locate your nearest dealer for parts, pricing or technical information, use the Dealer Locator at [CentralBoiler.com](http://CentralBoiler.com).

Download the parts and accessories  
catalog at [CentralBoiler.com/pdf/  
catalog-parts.pdf](http://CentralBoiler.com/pdf/catalog-parts.pdf)

# Meet owners of Central Boiler furnaces.



“After considering other brands, I’m glad I chose my Central Boiler. I will be adding my newly constructed shop this heating season. Looking forward to fuel and electric savings for years to come.”

- Miles, MN

“Our new Central Boiler system is without a doubt the finest wood burning system we have ever had the pleasure of using. The ease of operation, the efficiency, safety and the end result of a steady, dependable heat source provided by our Central Boiler stove surpass anything we have encountered in the past 50 years of wood burning as a heat source.”

- Justin, MN

“When I purchased my small business my fuel oil bill was \$6,750. We decided to put in a Central Boiler system. I’ve figured with the current cost of fuel oil we have already paid for the cost of the boiler 1.5 to 2 times and now heat our business virtually for FREE.”

- Wendy, MN

“I purchased a Central Boiler outdoor wood furnace in May 2009. I can report that I am very pleased with its operation, efficiency, and the overall quality of the stove. After seeing 3 or 4 other brands in operation at neighbor’s and friend’s farms, I’m convinced that the furnaces being constructed by Central Boiler are top of the line!”

- Dave, MN

“We love our Central Boiler outdoor furnace and should have gotten one ten years ago. Our grandkids were allergic to the smoke from our old indoor wood stove, but we don’t have to worry about that anymore with our Central Boiler. Everyone should buy a Central Boiler if they heat with wood.”

- Rhoda and Gary, KS



“I generally don’t smile much, but with the propane savings and now being able to heat my shop with a Central Boiler, I have much to smile about. Thank you for developing such a great product. Looking for steady savings in the many years to come.”

- Clarence, MN



“I wanted to send a little note and let you know how awesome this boiler has been. I started the fire back in September. It is now March and I haven’t had to restart it since. All I’ve had to do is add wood and remove a few ashes. I’ve done the math and this thing will pay for itself in less than 3 years. The propane man came up twice, but turned around both times and went to the neighbors instead!”

- Boudie, MT

“This is my second winter with the Central Boiler and my only regret is that I didn’t buy it sooner.”

- David, IL

“We have had our 6048 model one year this month. Our heat and hot water has been \$0.00 for a year!!! We normally used fuel oil that stunk and I could not turn the heat on any higher than 67 because I could just not afford it. At today’s fuel prices it won’t be long before it will be paying me!!! Thanks Central Boiler for having such an awesome product!”

- Lannette, IN

Read, watch and hear more at [CentralBoiler.com](http://CentralBoiler.com)

# Classic Model Lineup



## CL 4030 TITANIUM SERIES

Door..... 20" x 20"  
 Firebox..... 40" x 30" x 26"  
 Heat Transfer Area .....52 sq ft  
 Weight..... 1140 lbs  
 Water Capacity ..... 140 gal.  
 3/4" Supply/Return Ports .....2 ea

Included with outdoor furnace - Water Test Kit, Chimney Restrictor and two 4-foot chimney sections

Dual Fuel Ready models available.



## CL 5036 TITANIUM SERIES

Door..... 23" x 23"  
 Firebox..... 50" x 36" x 30"  
 Heat Transfer Area .....74 sq ft  
 Weight..... 1492 lbs  
 Water Capacity ..... 196 gal.  
 3/4" Supply/Return Ports .....2 ea

Included with outdoor furnace - Water Test Kit and two 4-foot chimney sections

Replaces up to 300 gallons of fuel oil per month.

Dual Fuel Ready models available.



## CL 6048 TITANIUM SERIES

Door..... 23" x 31"  
 Firebox..... 60" x 48" x 36"  
 Heat Transfer Area .....119 sq ft  
 Weight..... 2140 lbs  
 Water Capacity ..... 393 gal.  
 3/4" Supply/Return Ports .....2 ea  
 1-1/4" Supply/Return Ports .....1 ea

Included with outdoor furnace - Water Test Kit and two 4-foot chimney sections

Replaces up to 600 gallons of fuel oil per month.

Dual Fuel Ready models available.



## CL 7260 TITANIUM SERIES

Door..... 30" x 40"  
 Firebox..... 72" x 60" x 40"  
 Heat Transfer Area .....170 sq ft  
 Weight..... 3336 lb  
 Water Capacity ..... 764 gal.  
 1-1/4" Supply/Return Ports .....2 ea

Included with outdoor furnace - Water Test Kit, Chimney Band Clamp Kit (2), Chimney Base Bracket Kit, Firebox Door Draft Inducer Kit and three 4-foot chimney sections

Replaces up to 1,500 gallons of fuel oil per month.

Use the interactive Savings and Sizing Calculator at [CentralBoiler.com](http://CentralBoiler.com) to find the model for your heating needs.

## Color Options



FOREST GREEN



CHARCOAL



TAUPE

NOTE: The Pallet Burner and CL 7260 are only available in charcoal.

## PALLET BURNER

Door..... 54" x 50"  
 Firebox..... 72" x 66" x 54"  
 Weight..... 4880 lb  
 Water Capacity ..... 556 gal.  
 1-1/4" Supply/Return Ports .....2 ea

Included with outdoor furnace - Water Test Kit, Chimney Band Clamp Kit (2), Chimney Base Bracket Kit, Firebox Door Draft Inducer Kit (2), Side Draft Inducer Kit and three 4-foot chimney sections

- Dual Fuel Ready is standard.
- One year warranty.
- Available in charcoal only.

NOTE: The Pallet Burner is not a Classic model.



The business solution for high-capacity commercial or industrial use. Burn pallets, wood remnants, cord wood, non-treated wood packing crates and more. Large door openings allow for forklift loading.

## Furnace Base Dimensions

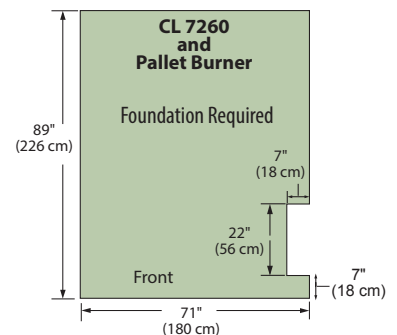
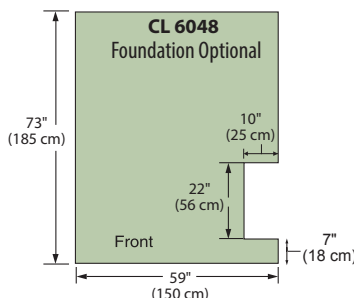
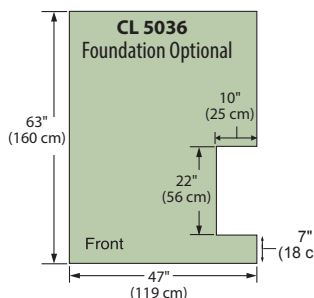
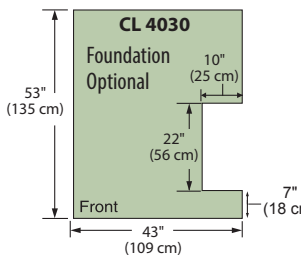

Furnace must be installed on a non-combustible surface or foundation that incorporates an enclosure that will prevent supply and return lines from any possible exposure to sunlight, fire, or physical damage that may be caused by an occurrence outside the furnace enclosure.

# Choose the right Central Boiler outdoor wood furnace for your application.

The Best Way to Size Your Furnace – Using Previous Heating History Including Water Heater					
Fuel Type	Fuel Oil	Propane	Natural Gas	Electricity	Wood <sup>†</sup>
Units	gallons	gallons	cubic feet, therms	kilowatts	cords
Units per Month					
Multiplier	x 1.18	x 0.78	x 0.0087/cu.ft x 0.87/therm	x 0.037	x 150
Sizing Value					

**If you have New, Well-Insulated Buildings<sup>††</sup>**

New well-insulated buildings with R28 walls, R40 ceilings, insulated basement walls. Normal sizing allows for one picture window and one patio door. Calculation does not allow for extremely large glass or air exchange heat losses. Buildings that are not well insulated are not applicable in this calculation. Use previous heating history to determine sizing.

We recommend you complete a heat loss estimate (e.g., Hydronics Institute - form 1504WH).

Total sq. ft.	
Multiplier	x 0.06
<b>Total Sizing Value</b>	

**Total Sizing Value** →

Compare your **Total Sizing Value** to the **Suggested Sizing Range** for the listed models.

Furnace	Suggested Sizing Range
CL 4030	0-170
CL 5036	0-355
CL 6048	250-710
CL 7260, Pallet Burner	500-1800

<sup>†</sup>Full cords of medium to high-quality wood.

<sup>††</sup>Improperly insulated radiant slab heating can dramatically affect sizing requirements and heat load.

Be sure to consult your dealer when sizing. Previous heating efficiencies and heat loss need to be considered when sizing a furnace. This is only a guideline.

This sizing worksheet calculation estimates the existing fossil fuel (heating oil, propane, natural gas) heating equipment performing at 75% efficiency.

## Factors that affect your fuel burn rate

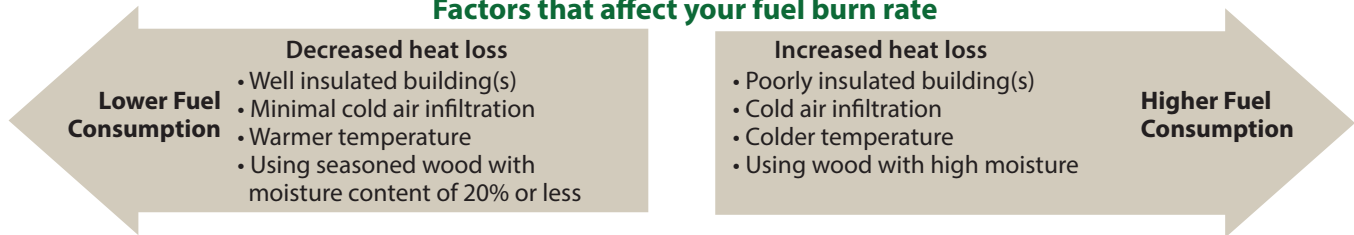

## BURN LESS WOOD WITH SEASONED WOOD

Btu's Lost when Burning High Moisture Content Wood

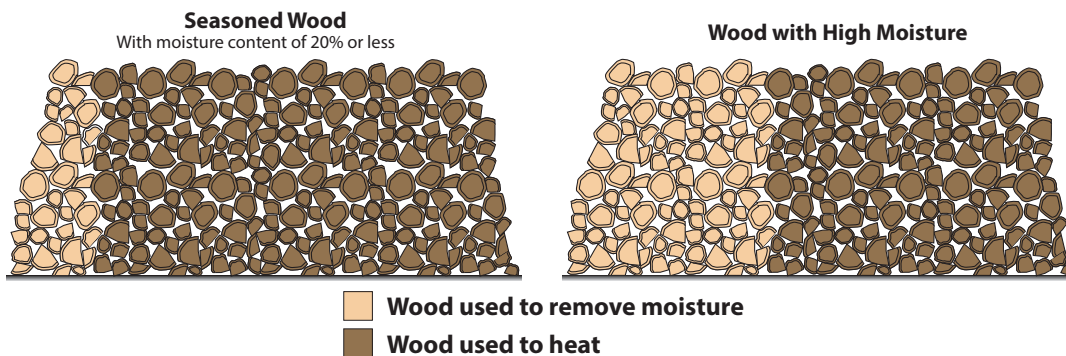

The difference between a full firebox load of 20% moisture wood and 50% moisture wood is up to six and a half gallons of water.

## LEADERS IN PRODUCT QUALITY, DESIGN AND INNOVATION

Central Boiler traces its roots back to 1984 in a workshop just south of Greenbush, Minnesota. There, a single idea and some welded pieces of metal would grow into a company that is recognized today as North America's largest manufacturer of outdoor furnaces. The company's innovations and patents come from people who take a little more time, pay a little more attention and go a little further to make sure that every Central Boiler product is ready to meet the demands of the real world.

## AUTHORIZED CENTRAL BOILER DEALERS LOCATED ACROSS THE U.S. AND CANADA

When you're looking for a wood heating system, a Central Boiler dealer is there to answer questions, provide you with literature about Central Boiler outdoor wood furnaces and help you choose the model right for your heating needs.

To locate a Central Boiler dealer in your area, visit the dealer locator at **CentralBoiler.com**.

**In the U.S., this appliance is for  
non-residential applications only.**

*Using wood as a heating fuel is endorsed by the U.S.  
Forestry Service.*

20502 160th Street • Greenbush, MN 56726

(800) 248-4681 or (218) 782-2575

**CentralBoiler.com**

© 2024 Central Boiler

®™ Trademarks of Central Boiler, Inc.

Printed in the United States 03/24

For the maximum performance and life of your furnace, always insist on using Central Boiler authorized system parts and accessories.

See Owner's Manual for proper chimney height and installation. Minimum chimney height is determined by proximity to other buildings. Consider location and direction smoke may travel with prevailing winds before installing your furnace.

Content of this brochure is information in possession of Central Boiler at the time of the design of this publication and may not represent what was previously manufactured. Product specifications and appearance subject to change.

Must be installed in accordance with all applicable codes and regulations.

Operating an outdoor furnace may not be suitable to some individuals' abilities or lifestyles. Be sure to review the Owner's Manual for the appliance with your dealer. Ask your dealer about Outdoor Furnace Best Burn Practices.

p/n 9000707 • REV. D - MARCH 2024



## FREE 25 YEAR LIMITED WARRANTY

A **free 25 year limited warranty** is available if your Classic is registered at the time of purchase. Central Boiler leads the industry with its commitment to stand behind its outdoor wood furnaces. See Warranty Registration form for details.

**Your Authorized Central Boiler Dealer**